

Distribution Boards - 12 & 20 Way



20-Way Plastic

(not populated / prewired - image for illustrative purposes only)



20-Way Steel

(not populated / prewired - image for illustrative purposes only)



12-Way Steel

(not populated / prewired - image for illustrative purposes only)

Features

- Aesthetically pleasing board for housing circuit breakers, switch disconnectors and earth leakage units
- Mounting tray, metal or plastic, vertically and horizontally adjustable
- Optional cover flaps available
- Earth and neutral bars provided
- Escutcheon / safety blanks available
- Conduit knockouts provided
- White coloured finish
- Flush mount
 - Choice of 12-way and 20-way, to accommodate 13 Mm width products
 - 12-Way available in steel or plastic
 - 20-Way available in steel or plastic
- Surface mount:
 - 13-Way (CBI Mini Rail)
 - 13-Way available in plastic only
- Mounting tray with CBI Mini Rail
- Manufactured from durable engineering plastic

Applications

- Residential
- Commercial

Optional Accessories

- Plastic hinged cover
- Front cover
- Circuit breakers
- Switch disconnectors
- Earth leakage units
- QAT-TRDM timers
- Energy Control Units (ECUs)

Technical Data

Distribution Boards	Description
Product Type	20 Way – 20 x 13 mm modules 12 Way – 12 x 13 mm modules 13-Way - 13 x 13 mm modules
Conduit Knockouts – 12-Way	3 x 20 mm top and bottom 2 x 20 mm on both sides
Conduit Knockouts – 13-Way	4 x 20 mm and 1 x 25 mm top 3 x 20 mm and 1 x 25 mm bottom 3 x 20 mm on both sides
Conduit Knockouts – 20-Way	5 x 20 mm and 1 x 25 mm top and bottom 2 x 20 mm on both sides

Distribution Boards - 12 & 20 Way

Ordering Information

Flush Mounting Distribution Boards		
Description	Std. Pack	Order No.
12 - Way Steel Distribution Board, complete with 1 Plastic Cover and 1 steel Tray (Mini Rail)	1	DBBOX12SP
12 - Way Steel Distribution Board, complete with 1 Steel Cover and 1 Steel Tray (Mini Rail)	1	3190796
20 - Way Steel Distribution , complete with 1 plastic cover and 1 Steel tray (Mini Rail)	1	DBBOX20SP
20 - Way Front Cover (including hinged dust cover)	1	3670107
20 - Way Steel Distribution Board, complete with Steel cover and 1 Steel tray (Mini Rail)	1	3190795

Surface Mount Distribution Boards		
Description	Std. Pack	Order No.
13 - Way Surface Mount Plastic Distribution Board (CBI Mini Rail)	1	NDB-CON001

Circuit Breaker Selection Chart

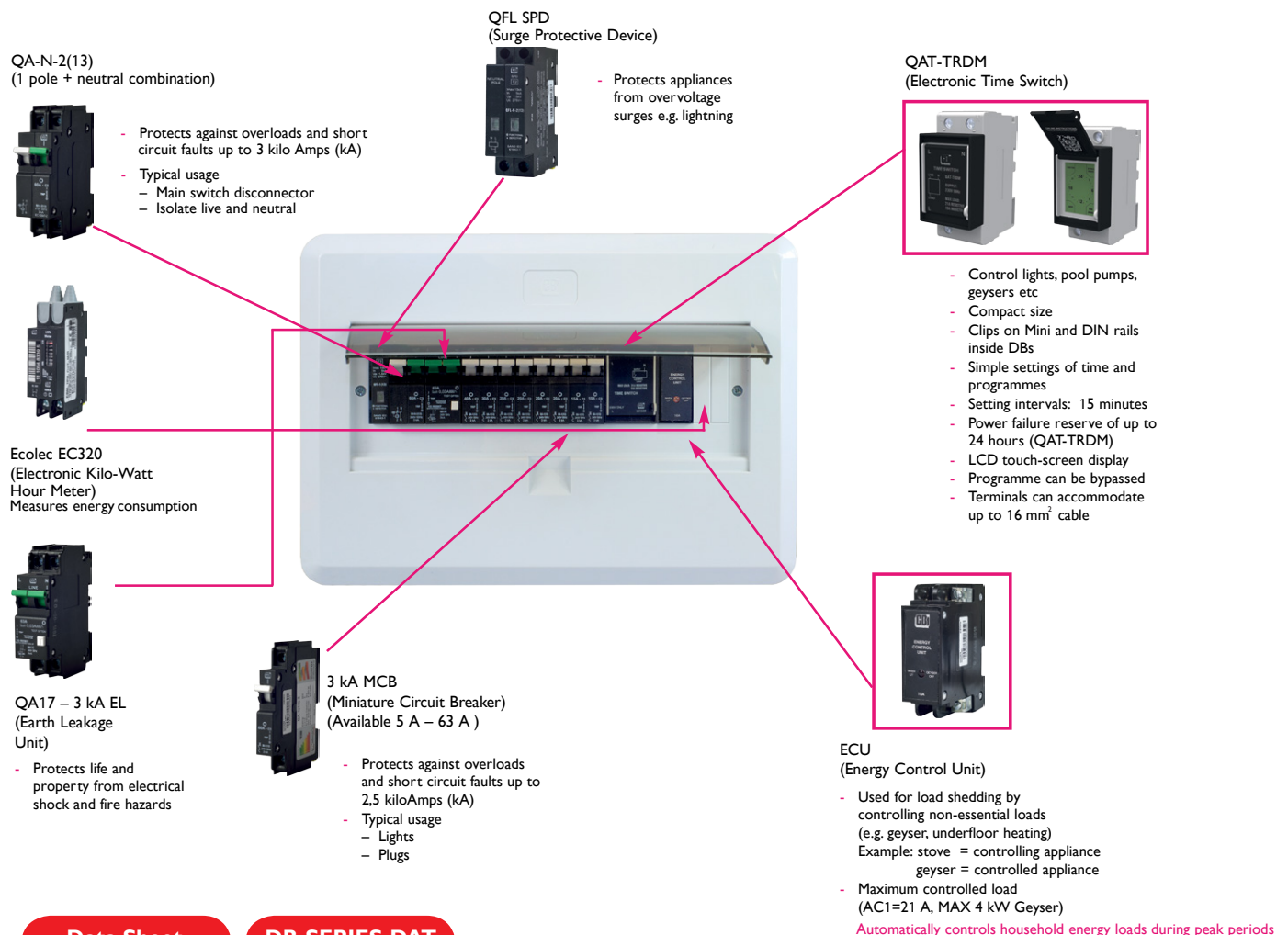

Distribution Boards - 12 & 20 Way

Dimensional Drawings: DBBOX12SP

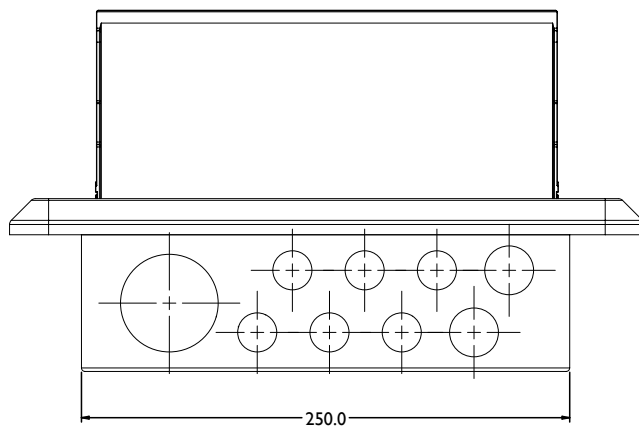
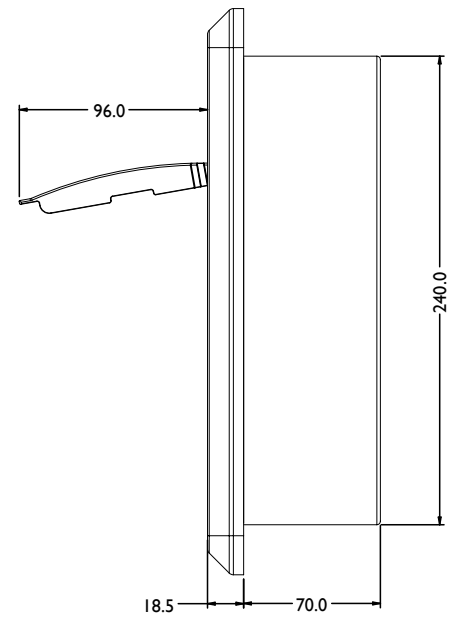
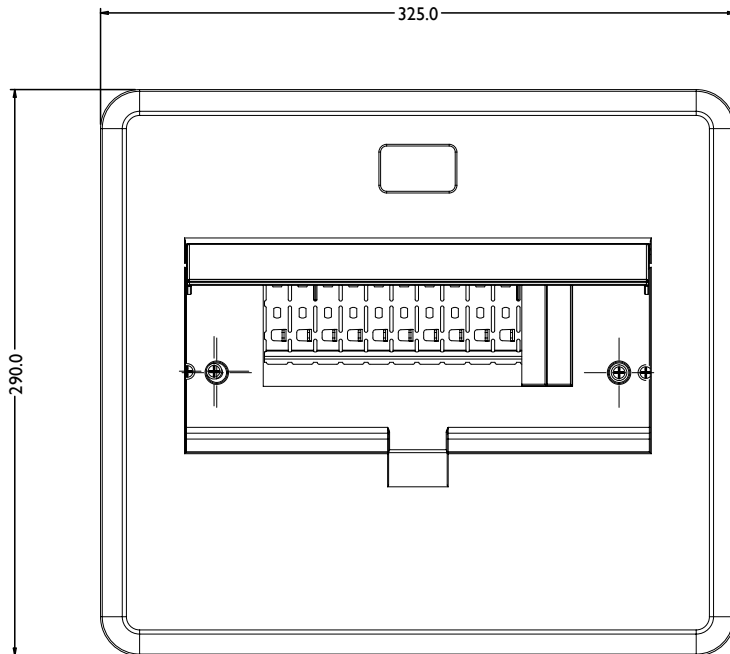

All dimensions in mm [inch]
Tolerance ± 0.4 unless otherwise specified

Distribution Boards - 12 & 20 Way

Dimensional Drawing: DBBOX20SP

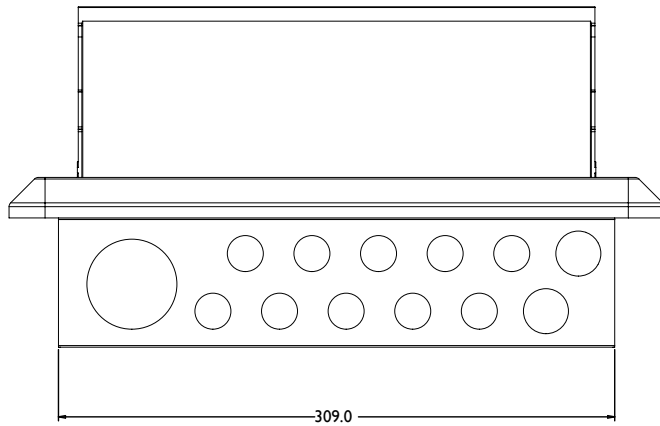
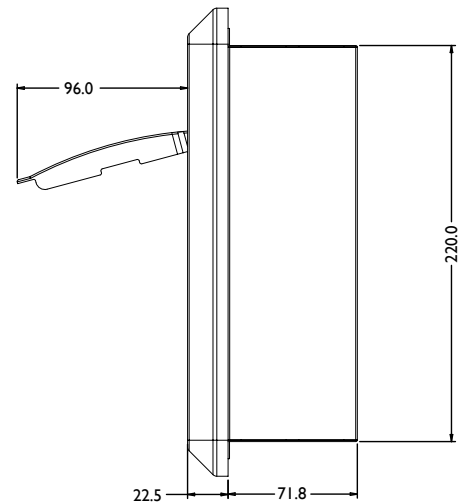
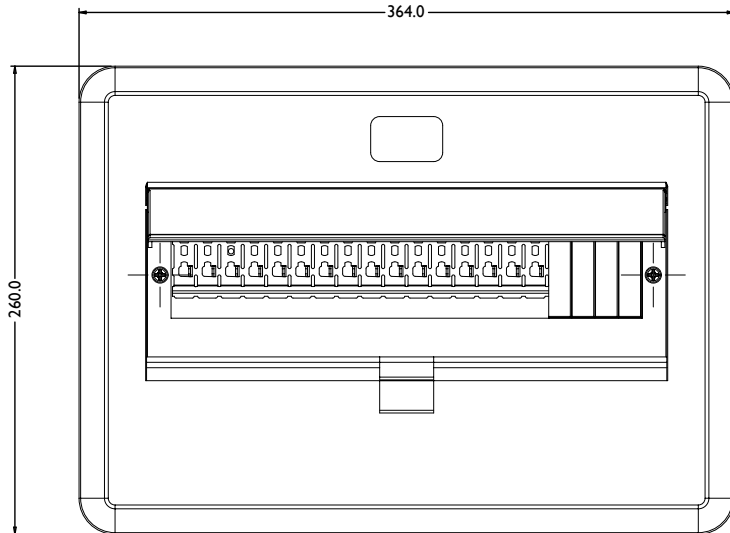

All dimensions in mm [inch]
Tolerance ± 0.4 unless otherwise specified

Please review our **Customer Terms and Conditions** on www.cbi-lowvoltage.co.za

All rights reserved. Unless otherwise indicated, all materials on these pages are copyrighted by CBI (Pty) Ltd. No part of these pages, either text or image may be used for any purpose other than personal use. Therefore, reproduction, modification, storage in a retrieval system or retransmission, in any form or by any means, electronic, mechanical or otherwise, for reasons other than personal use, is strictly prohibited without prior written permission. CBI (Pty) Ltd reserves the right to alter any details of this document without notice and while every effort is made to ensure the accuracy of the content, no warranty is given as to the accuracy of this document and no responsibility will be accepted for error or misinterpretation and any resulting loss.

© 2016.09 CBI (Pty) Ltd. All Rights Reserved.

AUSTRALIA

CBI-electric: Australia
27 Wedgewood Rd, Hallam
Victoria 3803 Australia
Tel: +61 3 8752 9300
Fax: +61 3 9796 5407
Email: sales@cbi-electric.com.au
Website: www.cbi-electric.com.au

SOUTH AFRICA

CBI-electric: low voltage
Tripswitch Drive Elandsfontein
Gauteng South Africa
Tel: +27 11 928 2000
Fax: + 27 11 392 2354
Email: cbi@cbi-electric.com
internationalsales@cbi-electric.com
Website: www.cbi-lowvoltage.co.za

USA

CBI-electric: North America
35 E. Uwchlan Ave Suite 328
Exton PA 19341 USA
Tel: +1 610 524 9949
Fax: +1 610 524 9945
E-mail: info@cbibreakers.com
Website: www.cbibreakers.com